

SET/OSK2

Capacitive oil-on-water detector



Installation and Operation Instructions



TABLE OF CONTENTS

1	GENERAL.....	3
2	CONNECTIONS AND INSTALLATION.....	4
3	ADJUSTING THE SWITCHING POINT	5
4	SERVICE AND REPAIR	6
5	TECHNICAL DATA.....	6

SYMBOLS



Warning / Attention



Pay special attention to installations at explosive atmospheres

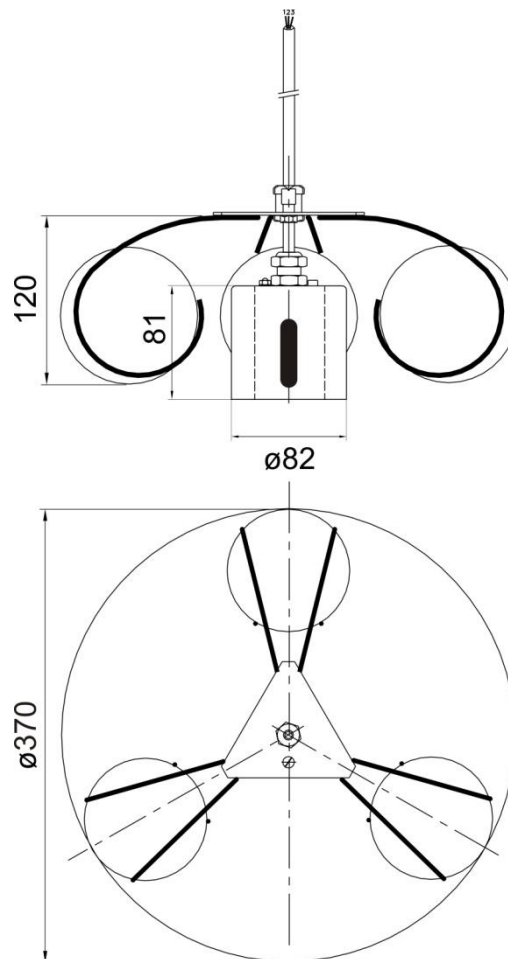

Fig. 1. SET/OSK2 dimensions

1 GENERAL

SET/OSK2 is a floating sensor, which provides an alarm of at least 15 mm thick oil or hydrocarbon layer on water. The most common applications are for example inspection shafts and different kind of basins with altering liquid level.

The sensor must be in the liquid all the time, otherwise it gives an alarm if it is left in the air.

SET/OSK2 is an apparatus of equipment group II, category 1 G. The sensor can be installed in zone 0/1/2 hazardous area.

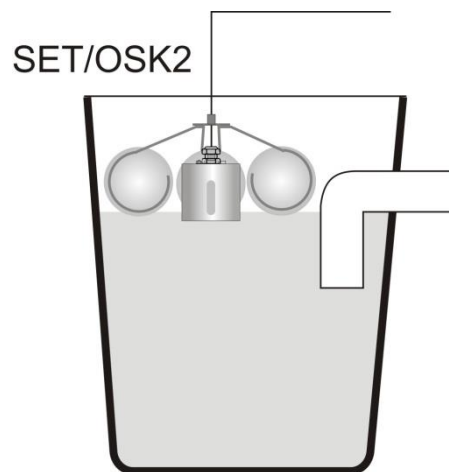

Fig. 2. Application; oil alarm in water inspection shaft

2 CONNECTIONS AND INSTALLATION

SET/OSK2 is equipped with a shielded 3-wire cable. The wires 1 and 2 shall be connected to the corresponding connectors (1 = +, 2 = -) in the control unit. Wire 3 shall be connected to equipotential ground together with the shield of the cable. Ground connector of the float frame shall be connected to equipotential ground. Please refer also to the installation instructions of the control unit.

The cable can be shortened or, when the control unit is located further away from the sensor, the cable can be extended with the junction box, which is included in the delivery.

The sensor floats freely on the liquid. **Therefore, please use long enough a cable to avoid hanging in the air in critical situations** (e.g. when the liquid level decreases).



When installing the sensor into an explosion hazardous area (0/1/2), the following standards need to be followed; EN IEC 60079-25 Electrical apparatus for potentially explosive atmospheres - Intrinsically safe electrical system "i", EN IEC 60079-14 Electrical apparatus for explosive gas atmospheres.

The sensor shall not be installed into a space where caustic vapour, gas or liquid, such as aromatic and chlorinated hydrocarbons or strong alkalis or acids, can damage the equipment.

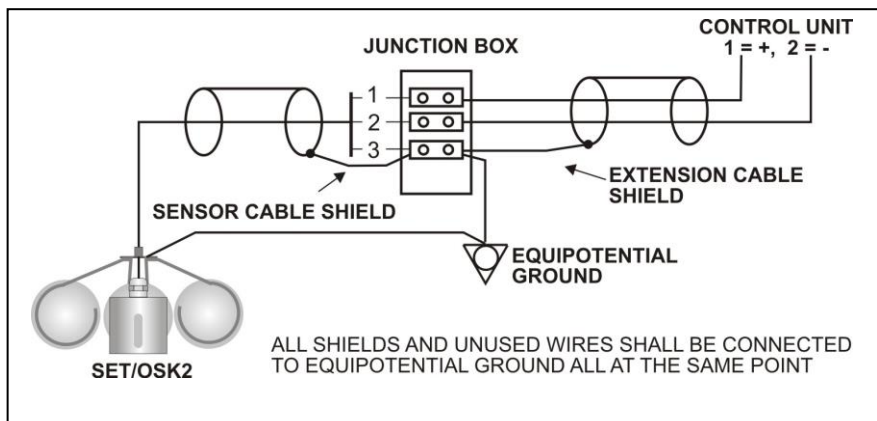

Fig. 3. Wiring example

3 ADJUSTING THE SWITCHING POINT

Adjusting the switching point is done as follows:

- Let the sensor float freely on the water
- Lift up the sensor as much as there is assumed to be oil or hydrocarbon layered on the water in alarm situation (the layer that should generate an alarm).
- if the control unit does not operate, adjust the SENSE trimmer slowly until the desired switching point is reached.

The sensitivity can also be decreased by adjusting the position of the sensor lower in the floating construction. Too sensitive settings cause unnecessary alarms if there are waves in the liquid.

To test the function of the sensor, lift up the sensor totally in the air. This should cause an alarm.

IF THE SENSOR DOES NOT WORK



If the sensor is located in a hazardous area an Exi-classified multimeter must be used and the Ex-standards mentioned in chapter 4. SERVICE AND REPAIR must be followed.

Make sure that the sensor is properly connected to the control unit. The voltage between connectors 1 and 2 in the control unit should be 10,5...12V.

If the voltage is correct, measure the sensor current as follows:

- Connect the ampere meter according to the figure below by disconnecting the conducting wire 1 from the central unit.
- Measure the current.

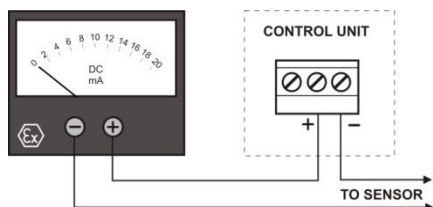

Fig. 4. Measuring the sensor current

Sensor current in different conditions:

clean and dry sensor in air	5... 6 mA
sensor entirely in water	12...16 mA

4 SERVICE AND REPAIR

The sensors must always be cleaned down and tested after oil alarm and when carrying out annual maintenance. For cleaning, a mild detergent (e.g. washing-up liquid) and scrubbing brush can be used.



Service, inspection and repair of Ex-apparatus needs to be done according to standards EN IEC 60079-17 and EN IEC 60079-19.

5 TECHNICAL DATA

SET/OSK2 sensor	
Control units	Labkotec SET control units
Cable	Shielded, oil-proof instrumentation cable 3 x 0,5mm ² Ø 5,7mm. Standard length is 5m. Can also be delivered according to the order with a maximum 15 m long cable. The cable can be extended with a similar instrumentation cable. The maximum pair resistance of the cable should not extend 75 Ω.
Temperature Operational Safety	-25 °C...+60 °C -25 °C...+60 °C
Materials	AISI 316, PVC
EMC Emission Immunity	EN IEC 61000-6-3 EN IEC 61000-6-2
IP-classification Sensor Junction box	IP68 IP67
Ex-luokitus ATEX Special conditions (X)	II 1 G Ex ia IIA T5 Ga VTT 03 ATEX 009X Ta = -25 °C...+60 °C The sensor cable can be extended with the junction box type LJB3-78-83 or LJB2-78-83.
Ex-connection values	U _i = 18 V I = 66 mA P _i = 297 mW C _i = 3 nF L _i = 30 μH U _N = 9...18 V
Operating principle	Capacitive
Manufacturing year: Please see the serial number on the type plate	xxx x xxxxx xx YY x where YY = manufacturing year (e.g. 19 = 2019)

EU DECLARATION OF CONFORMITY

We hereby declare that the product named below has been designed to comply with the relevant requirements of the referenced directives and standards.

Product Level sensor
SET/OS2, SET/OSK2

Manufacturer Labkotec Oy
Myllyhaantie 6
FI-33960 Pirkkala
Finland

Directives The product is in accordance with the following EU Directives:
2014/30/EU Electromagnetic Compatibility Directive (EMC)
2014/34/EU Equipment for Potentially Explosive Atmospheres Directive (ATEX)
2011/65/EU Restriction of Hazardous Substances Directive (RoHS)

Standards The following standards were applied:

EMC: EN IEC 61000-6-2:2019
EN IEC 61000-6-3:2021

ATEX: EN IEC 60079-0:2018
EN 60079-11:2012

EC-type examination certificate: VTT 03 ATEX 009X.

Notified Body: VTT Expert Services Ltd, Notified Body number 0537.

The revised harmonised standards have been compared to the previous standard versions used in the original type certification and no changes in the "state of the art" apply to the equipment.

RoHS: EN IEC 63000:2018

The product is CE-marked since 2003.

Signature This declaration of conformity is issued under the sole responsibility of the manufacturer. Signed for and on behalf of Labkotec Oy.

Pirkkala 4.8.2021



Janne Uusinoka, CEO
Labkotec Oy